

6.4 Decoders

- A decoder is a logic circuit that detects the presence of a specific combination of bits at its input.

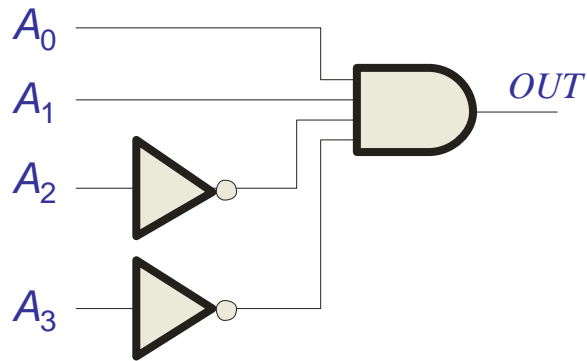

Active HIGH decoder for 0011

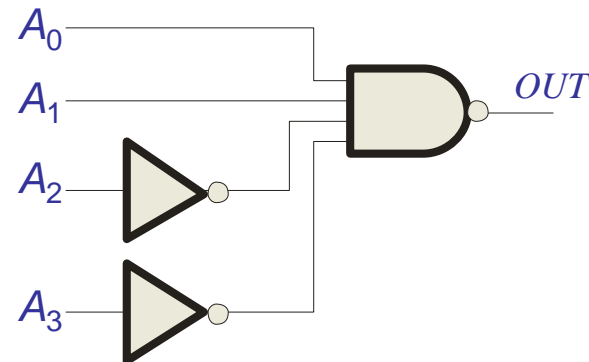

Active LOW decoder for 0011

4-to-16 Decoder

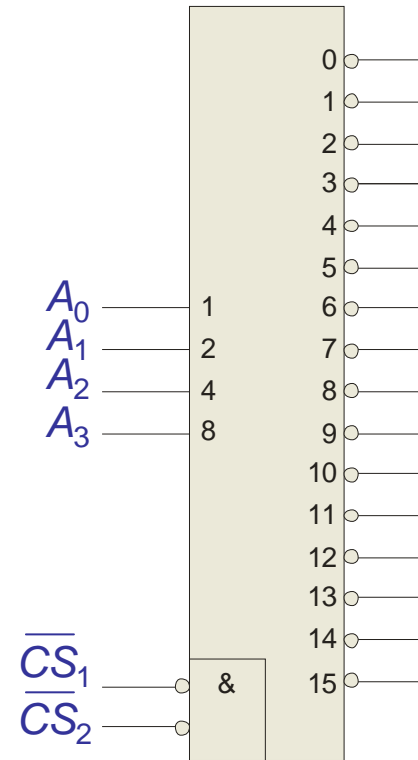
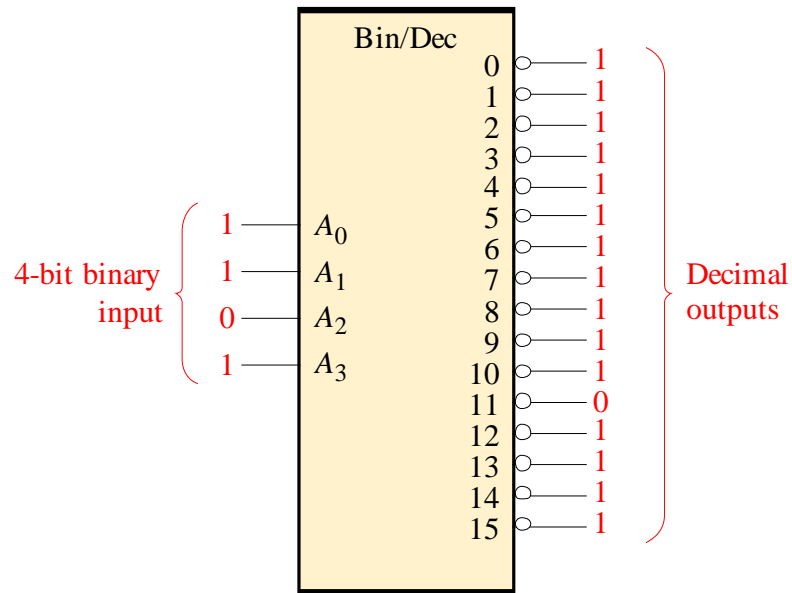

IC: 74HC154

Question: Use 74HC154 to implement the logic in order to support a 5-bit number.

BCD-to-Decimal Decoder

- BCD-to-decimal decoders accept a binary coded decimal input and activate one of ten possible decimal digit indications.
- IC: 74HC42

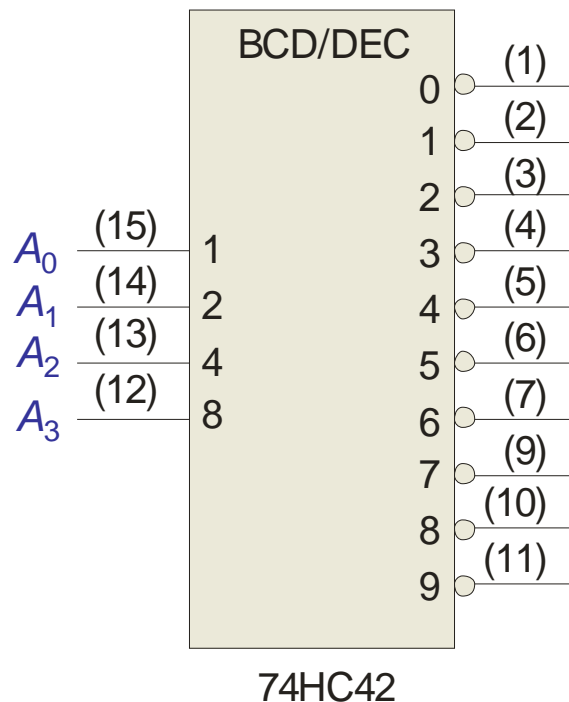

Question: Assume the inputs to the 74HC42 decoder are the sequence 0101, 0110, 0011, and 0010. Describe the output.

Answer: All lines are HIGH except for one active output, which is LOW. The active outputs are 5, 6, 3, and 2 in that order.

Question: Write truth table of output 0.

BCD-to-7-Segment Decoder

- IC: 74LS47
- BCD Inputs (D-A)
- 7-segment Outputs (\bar{a} - \bar{g})
- Ripple Blanking Input (RBI)
- Blanking Input/Ripple Blanking Output ($\overline{BI/RBO}$)
- Lamp Test (\overline{LT})
- Zero Suppression

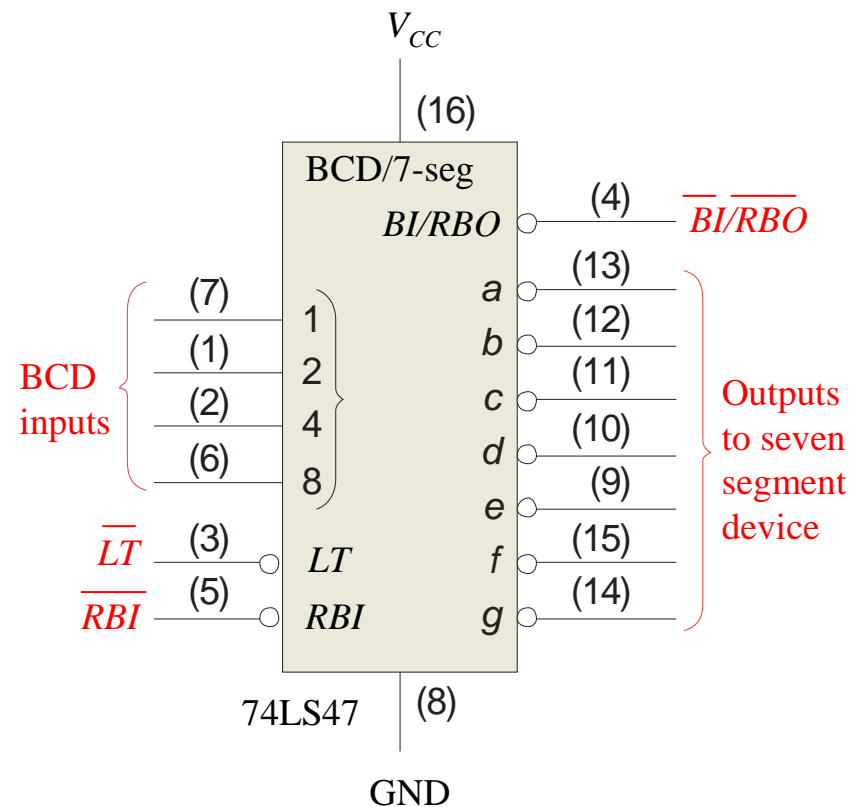

Illustration of Leading Zero Suppression

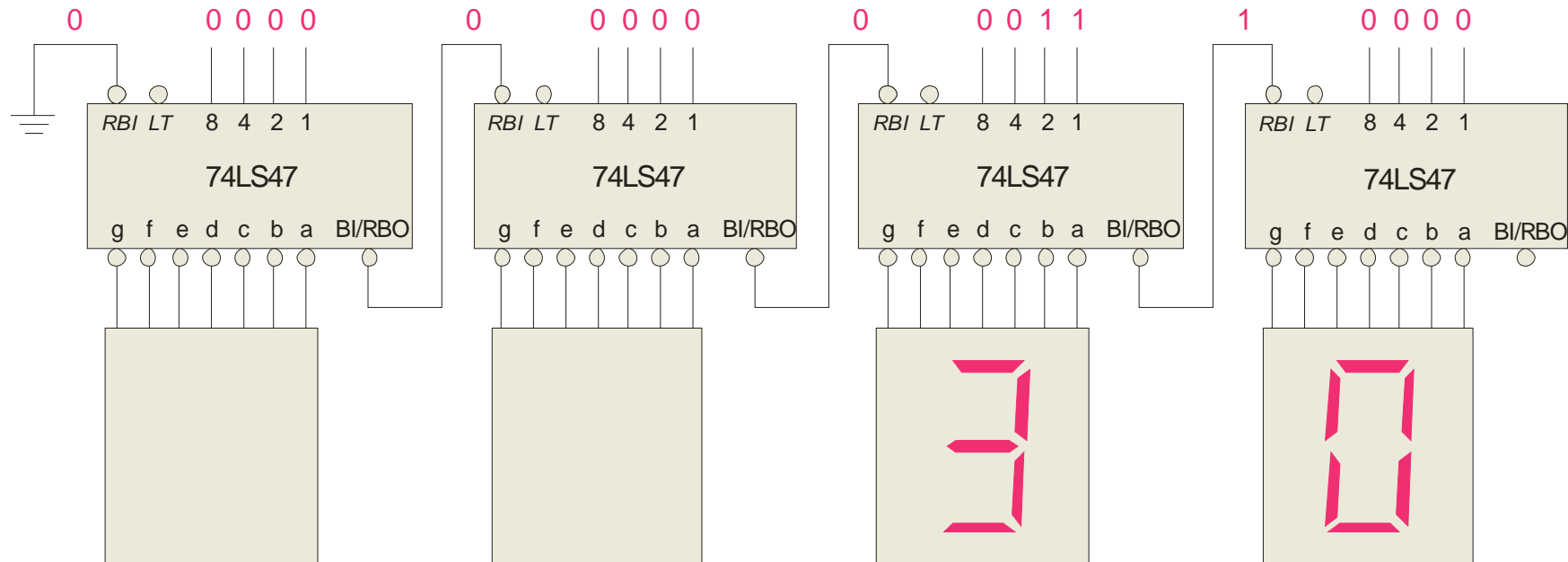
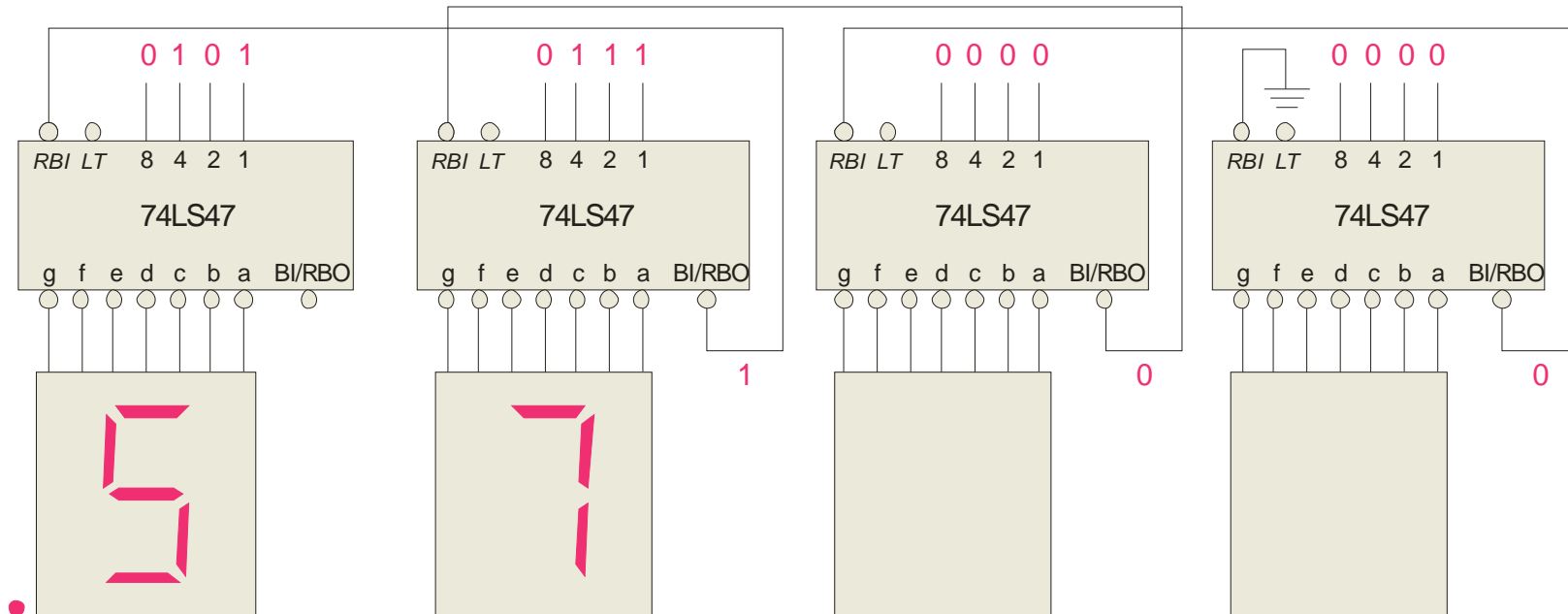
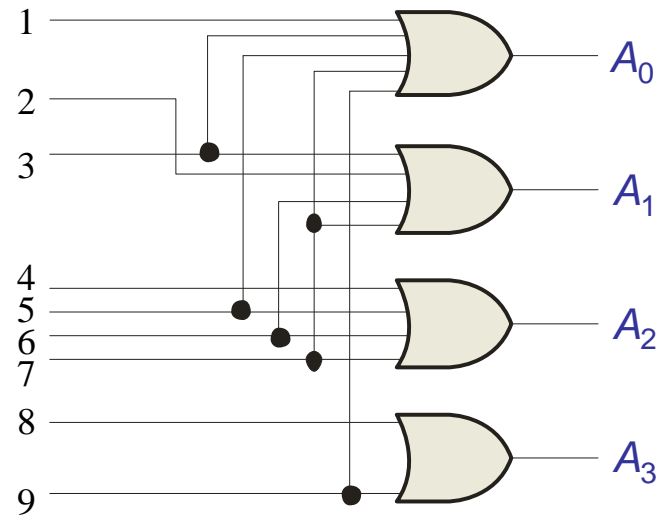

Illustration of Trailing Zero Suppression



6.5 Encoders

- An **encoder** accepts an active logic level on one of its inputs representing a digit, such as a decimal or octal digits, and converts it to a coded output, such as BCD or binary.
- IC: 74HC147 16-to-4 encoder (decimal-to-BCD)
- IC: 74F148 8-to-3 encoder



Example

- Show how the decimal-to-BCD encoder converts the decimal number 3 into a BCD 0011.

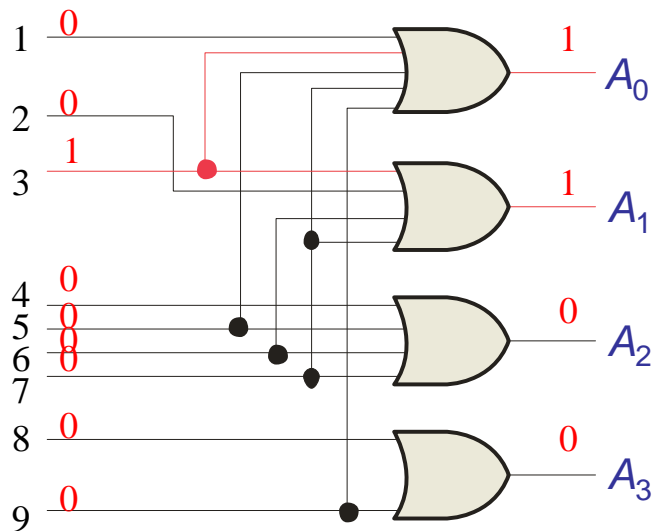

74HC147

- The 74HC147 is an example of an IC encoder. It has ten active-LOW inputs and converts the active input to an active-LOW BCD output.
- This device offers additional flexibility with a **priority encoder**.

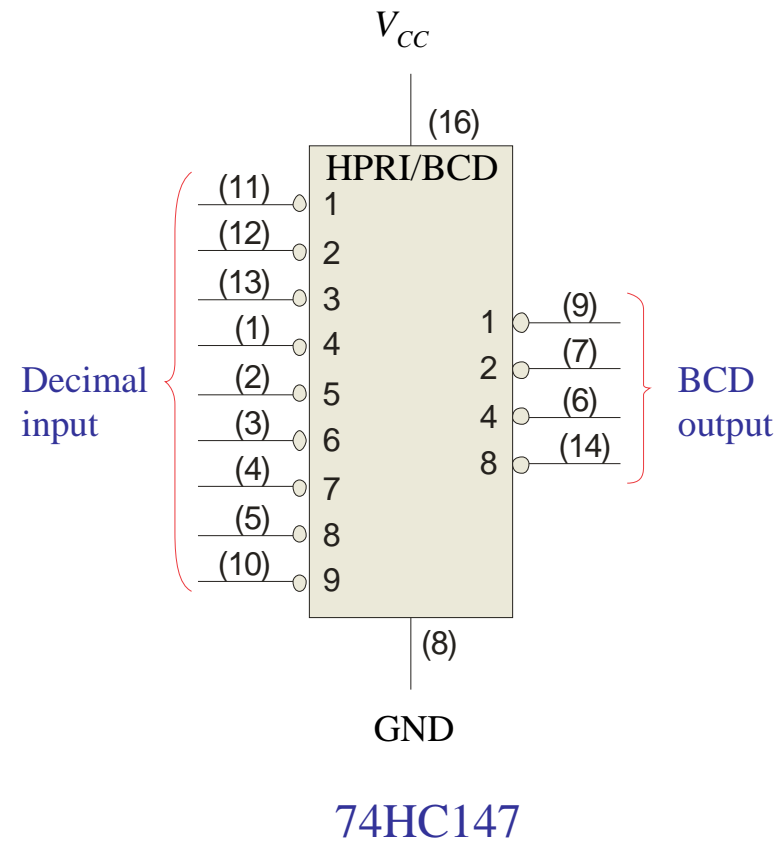

A Simplified Keyboard Encoder

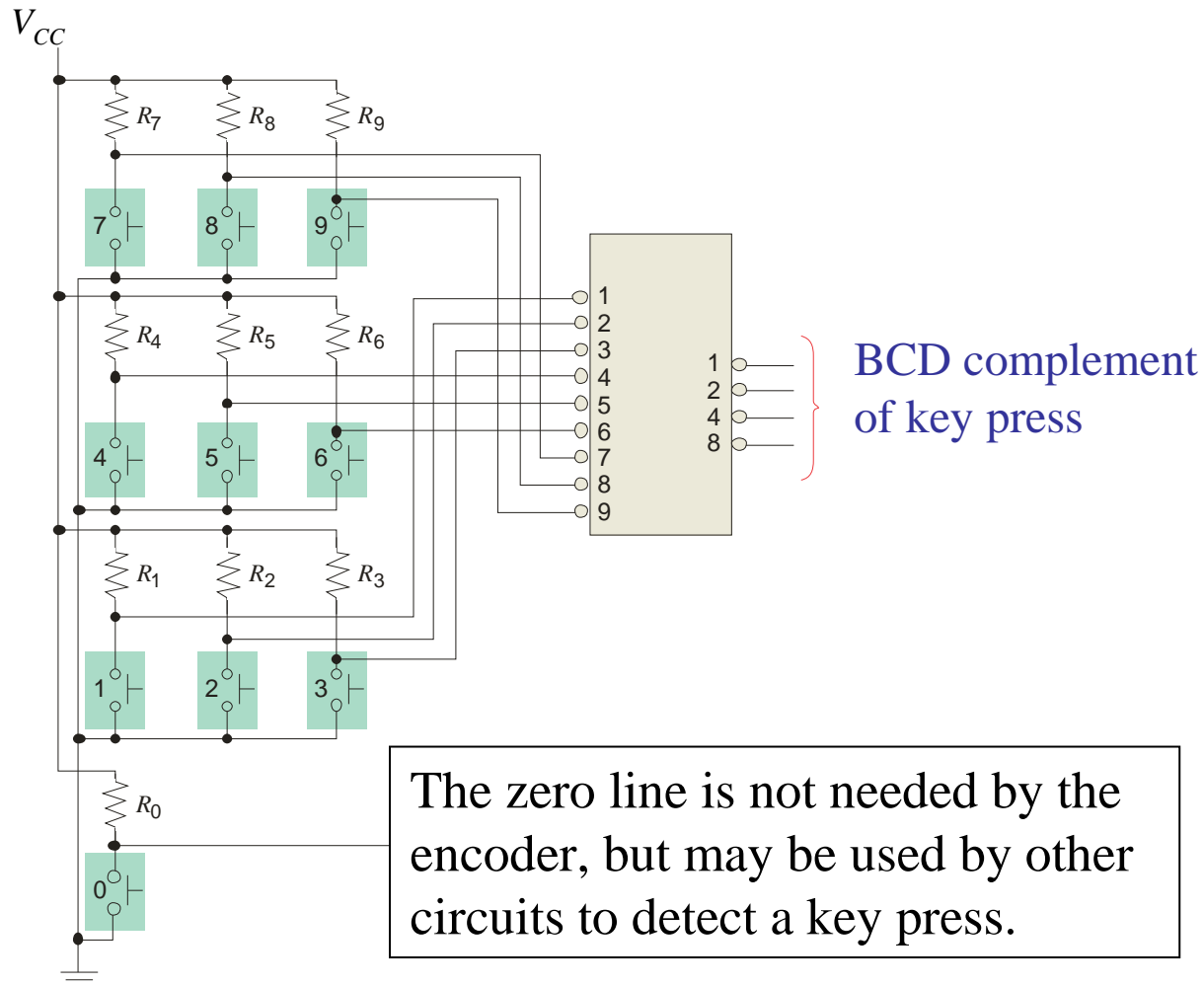

6.6 Code Converters

- BCD-to-BIN Conversion
- IC: 74184
- BIN-to-BCD Conversion
- IC: 74185

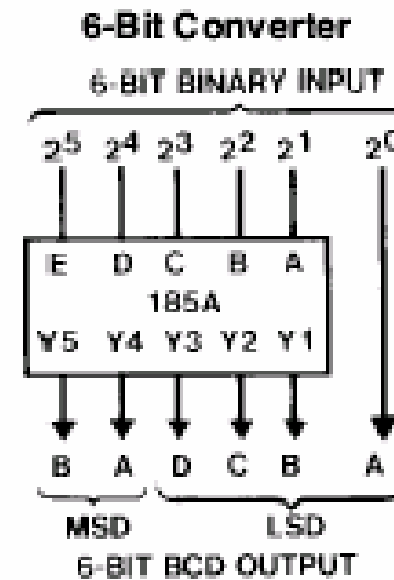
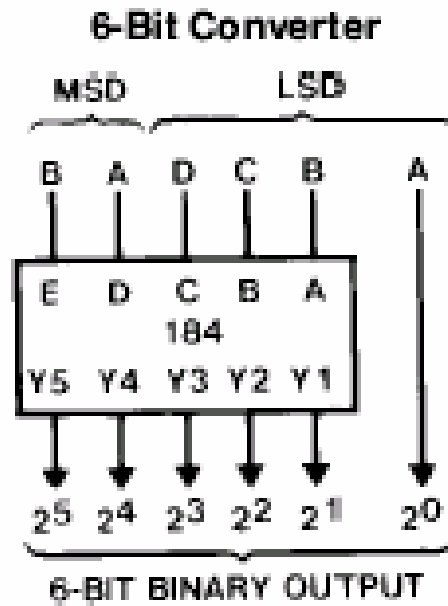

Code Converters (cont.)

■ BIN-to-Gray

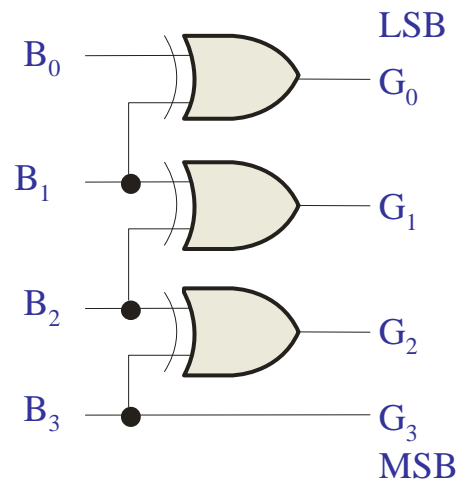

■ Gray-to-BIN

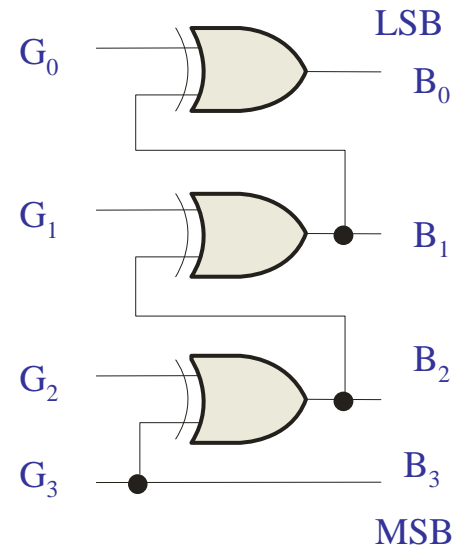

Question: Show the conversion of binary 0111 to Gray and vice versa.

6.7 Multiplexers (MUX)

- A multiplexer has several data-input lines and a single output line.
- It also has data-select inputs, which permit digital data on any one of the inputs to be switched to the output line.
- Another name is a data selector.
- IC: 74HC157 Quad 2-input MUX
- IC: 74HC151 8-input MUX

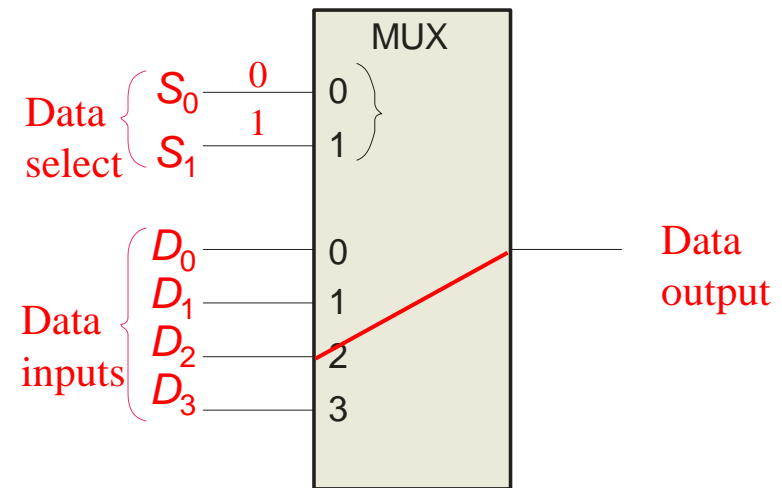

Question: Which data line is selected if $S_1 S_0 = 10$?



ICs

- 74HC157 Quad 2-input MUX
- 74HC151 8-input MUX

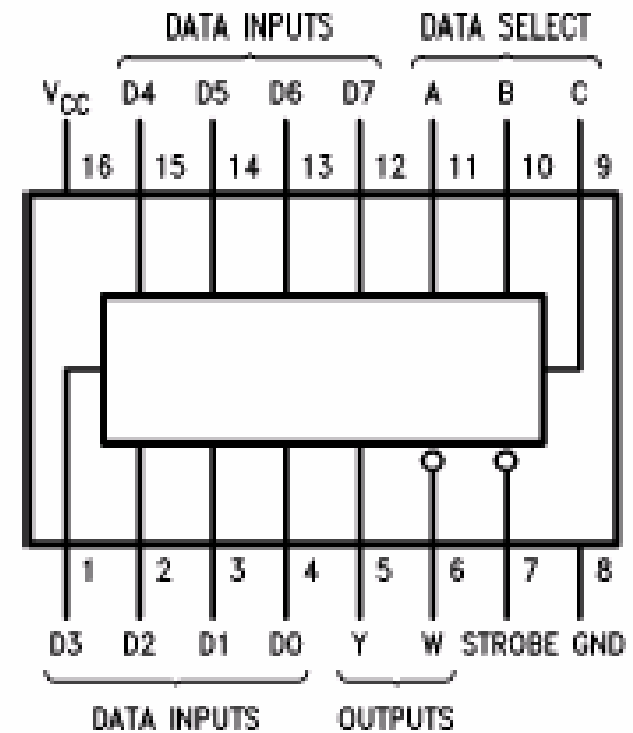
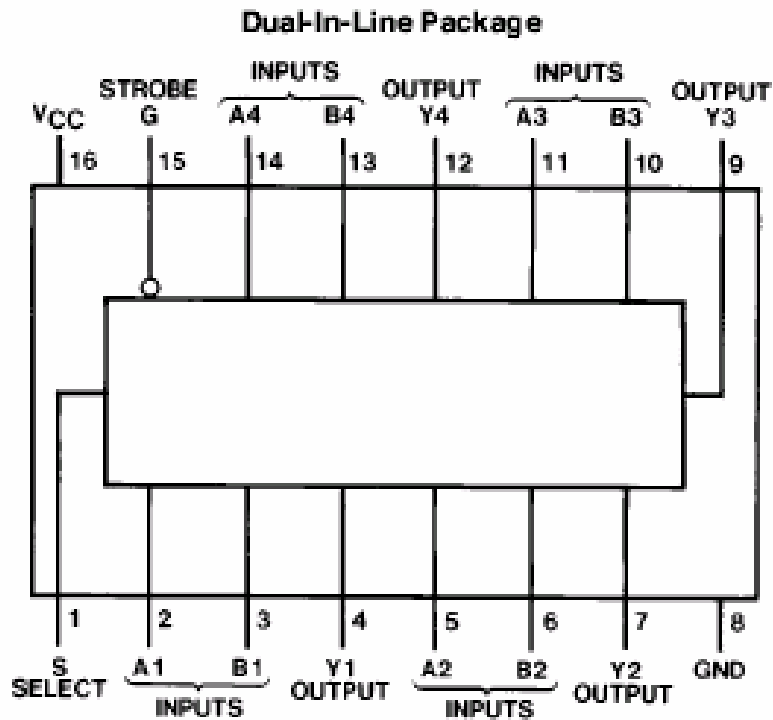

6.8 Demultiplexers (DEMUX)

- A DEMUX basically reverses the multiplexing function.
- It takes data from one input line and distributes to one of output lines depending on the select lines.
- Another name is a data distributor.
- IC: 74LS138 8-output DEMUX

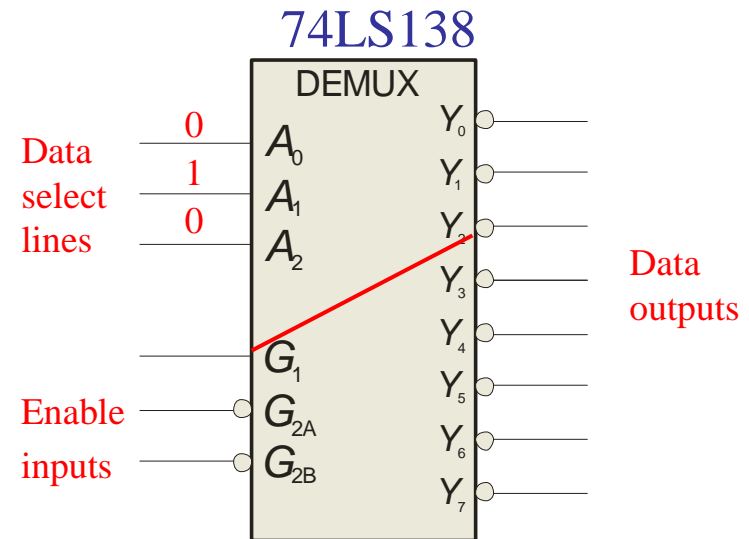

Question: Which data output is selected if $A_2A_1A_0 = 010$?

Example (DEMUX)

- Determine the outputs, given the inputs shown.

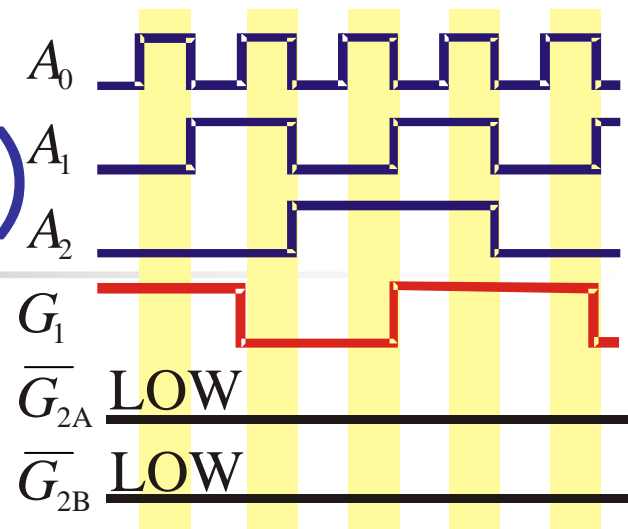
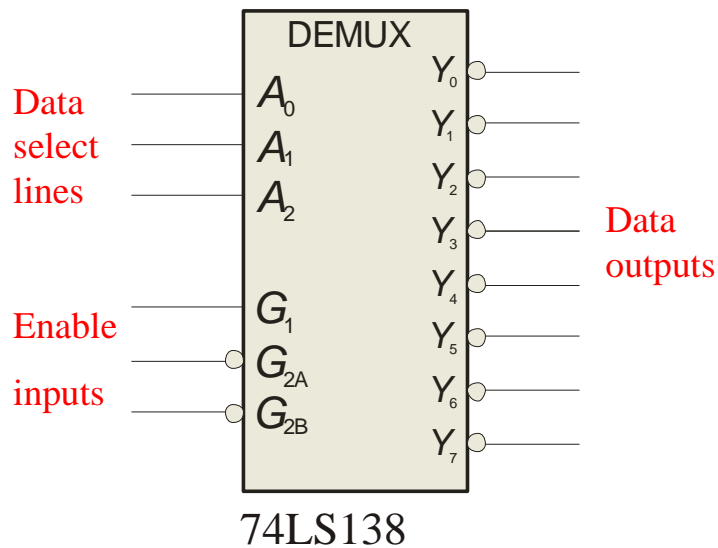

Y_0
 Y_1
 Y_2
 Y_3
 Y_4
 Y_5
 Y_6
 Y_7

6.9 Parity Generators/Checkers

- One method of error detections is to use parity.
- A parity bit is attached to a group of data in order to make the total number of 1s either even or odd.
- IC: 74LS280 9-bit parity generator/checker

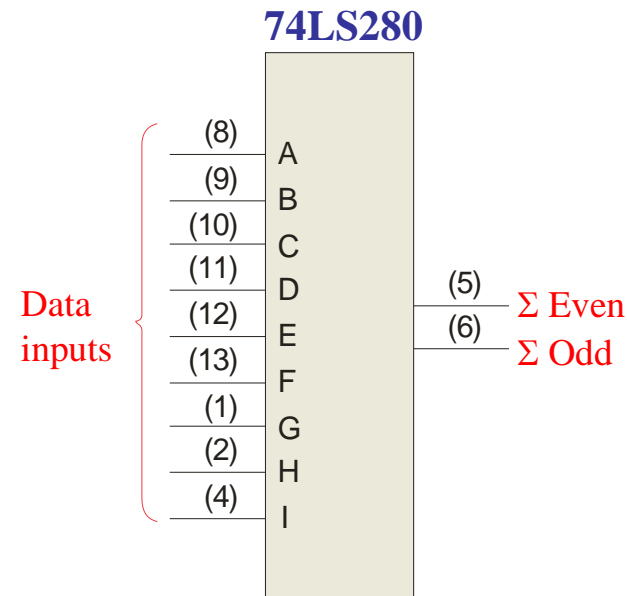

- Checker:

# of 1s on inputs	Σ Even	Σ Odd
0,2,4,6,8	H	L
1,3,5,7,9	L	H

Generator: To generate even parity, the parity bit is taken from the odd parity output. To generate odd parity, the output is taken from the even parity output.